

Yamaha

'03-'11 Kodiak & '04-'09 Bruin & 2007-2011 Grizzly 350/400/450 Winch Mount 2007-2011 Big Bear 400

Winch Mount PART # 100530

Kit Components:

Qty	Part Description
1.....	Winch Mount
1.....	Winch Spacer
4.....	5/16" x 1.00" Flat Head Bolt
4.....	5/16" Nylock Nuts
4.....	5/16" Flat Washers

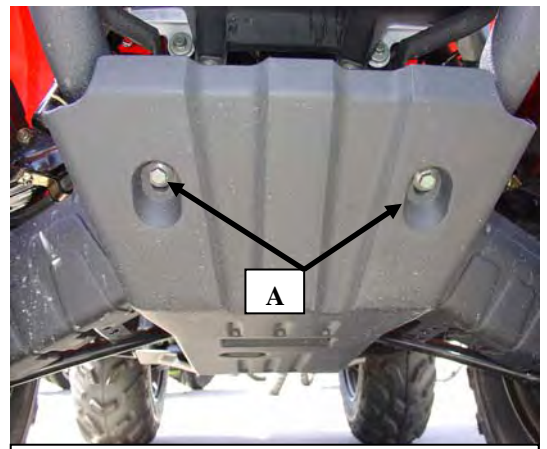

"Figure 1" Remove (2) Plastic Guard Bolts

INSTALLATION INSTRUCTIONS:

1. Remove the two bolts [A] from the bottom plastic guard as shown in "Figure 1"
2. Place winch into location on the front mounting tabs on the lower portion of the front bumper as shown in "Figure 2". With certain winches and machines this may be a very tight fit. Depending on what winch you have and what machine you have, you will need to get the winch put into position by putting the motor end of the winch in first with the top or bottom surface of the winch facing you as shown in "Figure 3". Once the winch is maneuvered into position you will then need to rotate the winch so that the mounting surface is down. This may need to be achieved by rotating it with the corner of the winch going into the space between the front and rear mounting tabs on your machine as shown in "Figure 4"
3. Once the winch is into location as shown in "Figure 2" you can then place the winch mount into location by slipping it between the winch and mounting tabs on the ATV frame as shown in "Figure 5".
NOTE: WITH SOME WINCHES YOU WILL BE REQUIRED TO MOUNT THE PLATE ON THE BOTTOM OF THE FRAME TABS TO LOWER THE MOTOR FROM HITTING THE UPPER FRAME TUBES.
4. If you have a 2-hole mounted winch (Superwinch and similar styles) you will be using the supplied Flat Head Screws as shown in "EXPLODED VIEW 1"
5. If you have a 4-hole mounted winch (Warn, Ramsey, and similar styles) you will only be using the winch mount that is supplied and the hardware that came with your winch to mount the entire assembly to your ATV as shown in "EXPLODED VIEW 2".

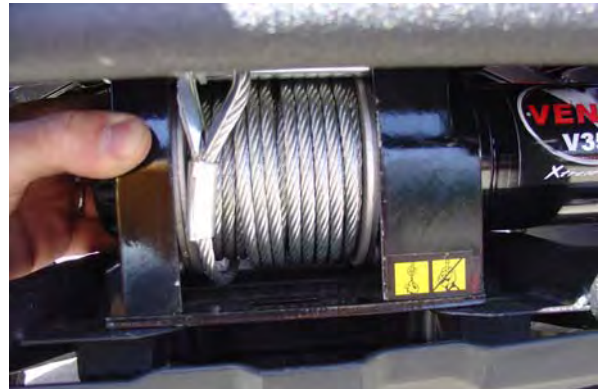

"Figure 2" Winch Location



"Figure 3"



"Figure 4" Rotate Winch Utilizing The Space Between The Mounting Tabs

6. If your winch is a 2-hole mounted winch as shown in “EXPLODED VIEW 1”, you can now bolt the mount to the frame using the supplied hardware by moving the winch around from side-to-side to access the mounting holes in the mounting plate.
7. With some 2-hole mounted winches, the supplied winch spacer will need to be placed between the winch and the winch mounting plate so that the motor will not interfere with the top and bottom tubes on the ATV bumper as shown in “EXPLODED VIEW 1” and in “Figure 6”.

NOTE: With all 4-hole mounted winches like Warn and Ramsey this spacer will not be used.
8. Mount your winch to the mounting plate and spacer (if used) with the hardware supplied with your winch.
9. Mount your Roller or Hawse Fairlead to the mount using the hardware that came with your fairlead or winch kit.
10. Reinstall the two bolts from Step 1.
11. Using the instructions provided with your winch, wire accordingly



“Figure 5” Put Winch Mount Into Location

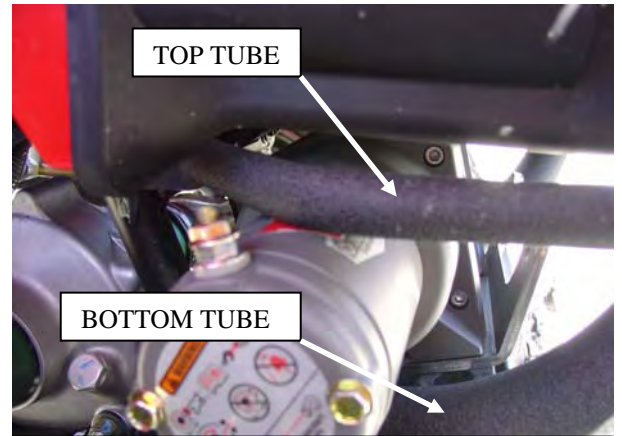

“Figure 6” Determine If Winch Spacer Is Needed

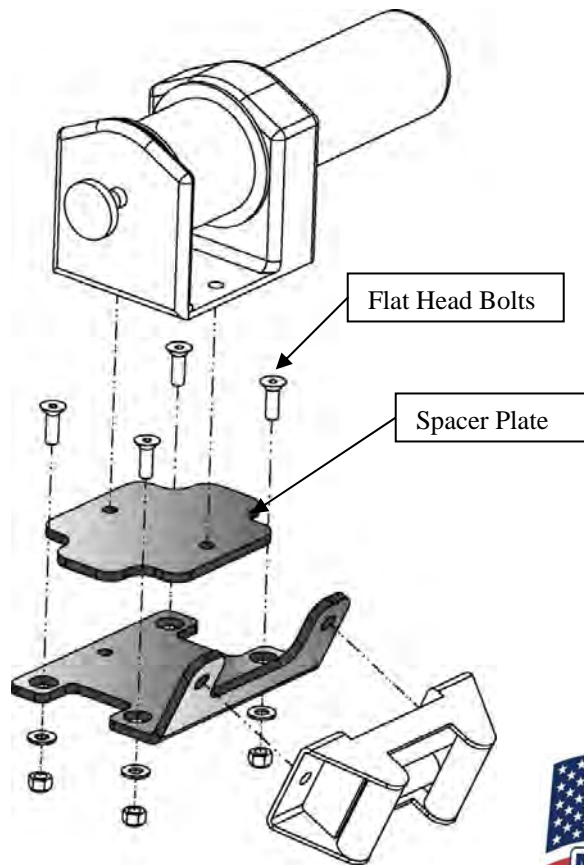

EXPLODED VIEW 1

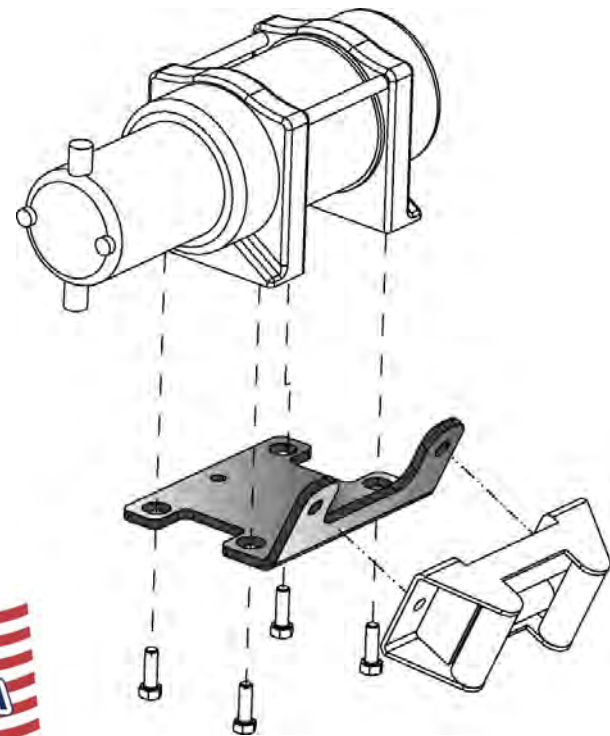

EXPLODED VIEW 2