

Polaris Hawkeye & 2008-2010 Sportsman 300/400 Winch Mount

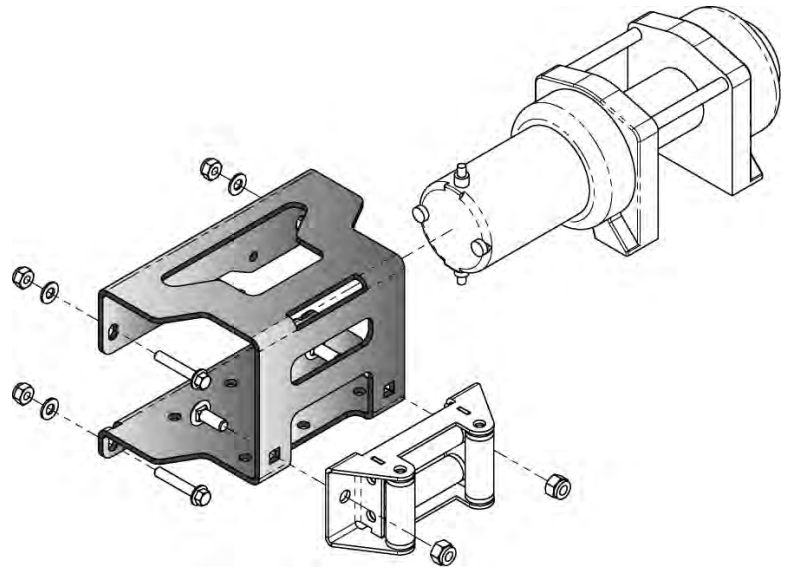

Winch Mount

PART # 100590

Kit Components:

Qty	Part Description
1.....	Winch Mount
2.....	3/8" x 1.00" Carriage Bolt Short Neck
2.....	3/8" Locking Hex Nuts
4.....	5/16"-18 X 1-3/4" Hex Flange Bolt
4.....	5/16"-18 Nylock Nut
4.....	5/16" SAE Flat Washer

INSTALLATION INSTRUCTIONS:

1. Disconnect the front headlights.
2. Remove the front bumper and grill assembly by removing the top (2) bolts and nuts (A), the (2) center nuts (B), and the bottom (2) bolts (C). "Figure 1"
3. Remove Radiator Guard if equipped.
4. Place the mount into location as shown in "Figure 2" and assemble using the supplied 5/16" Hardware or hardware removed from the radiator guard if equipped.
5. Place the supplied 3/8" Short neck Carriage bolts into position for the fairlead as shown in the exploded view above and then mount your winch to the mount using the hardware that was supplied with your winch.
6. Using the instructions provided with your winch, wire accordingly. *(Note: On the back side of our mount we supply a mounting location for the standard ATV winch electrical contactor. This is an optional location only. This is the standard OEM mounting location for the contactor)*
7. Connect the Red wire from your Mini-Rocker Switch to the ORANGE/WHITE Ignition wire under the handlebar pod.
8. Re-assemble the front bumper and grill components that were removed in Step 1. *(Note: There is a relief cut on the top of our mount for clearance of a plastic tab that is on the inside of the plastic bumper. This relief should provide enough clearance for the tab. If it does not you may need to trim some of the tap with a utility knife.)*
9. Re-connect your Headlight plugs.
10. Assemble your Fairlead to the mount using the included 3/8" nuts and the Carriage bolts from Step 4. *(Note: make sure you do not forget to wrought your cable thru the fairlead)*

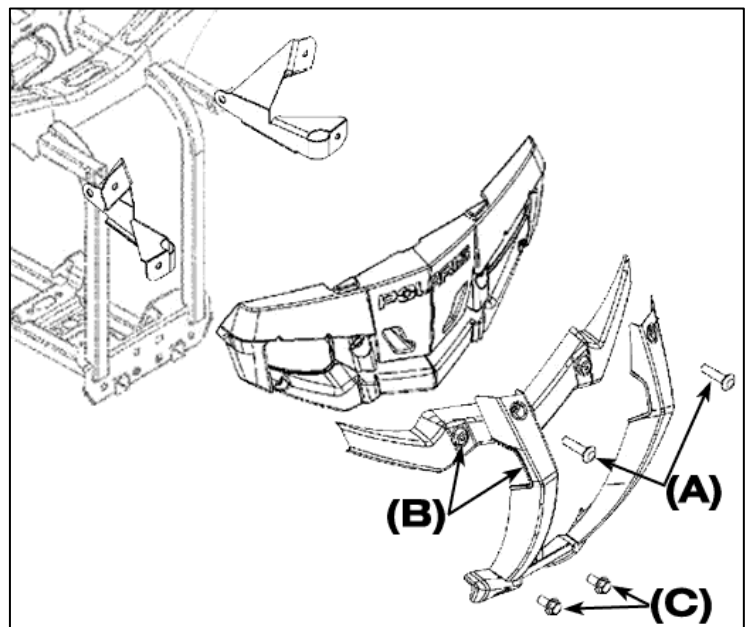

"Figure 1" Remove Front Bumper and Grill

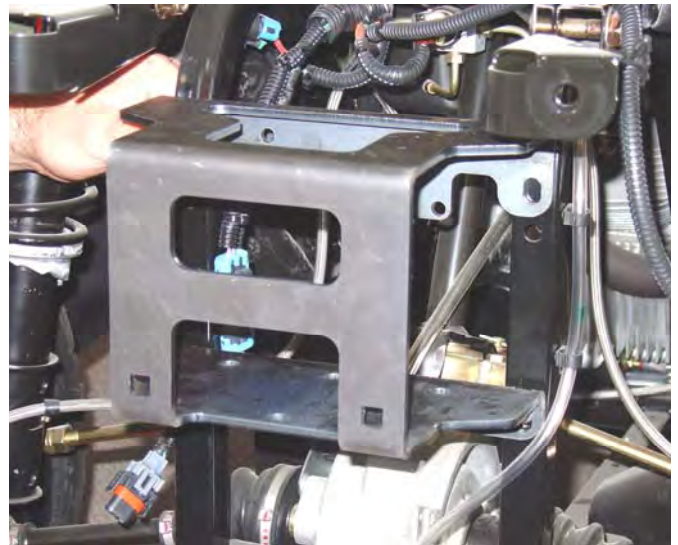

"Figure 2" Mount Location

