

'93-'00 Honda Fourtrax 300 2x4/4x4

93-00 TRX300FW 4x4 / 93-00 TRX300TW 2x4

Winch Mount

PART # 100665

Kit Components:

Hardware Kit # HK-035

<u>Qty</u>	<u>Part Description</u>
1.....	Winch Mount
2.....	5/16" X 1-1/4" X 1-3/4" U-Bolt
4.....	5/16" Nylock Nuts
4.....	5/16" Flat Washers
2.....	M8 X 25mm HHF Bolt
2.....	M8 X 25mm FH Bolt
2.....	5/16" X 1" FH Bolt

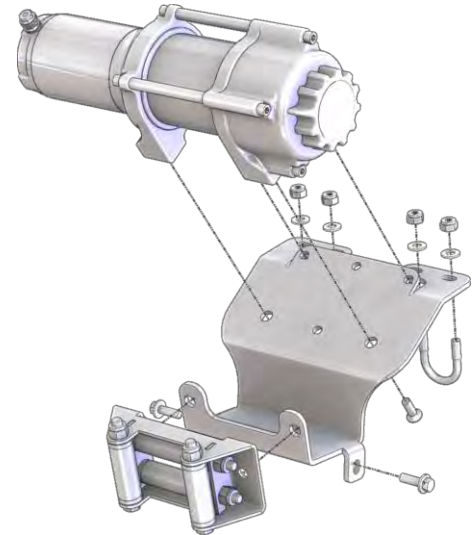

INSTALLATION INSTRUCTIONS:

1. Install your winch and fairlead to the winch mount using the hardware that was supplied with your winch and either M8 or 5/16" Flat Head Bolts supplied with the mount. Flat head bolts will be used in the larger winch holes as shown in exploded view.
2. Temporarily remove the front bumper assembly by removing the (8) mounting bolts that hold it on. At this time you will need to raise the front fender about 3" to create enough clearance for the winch assembly installation.
3. Place the Winch and Mount Assembly into position on the frame as seen in "Figure 1&2" (winch and fender not shown for clarity) Bolt the mount to the Frame using the supplied 5/16" U-bolts (B) and hardware but do not tighten at this time.
(Note: With some winches the rear black headlight cover on the motor side of the winch may need to be removed for winch clearance.)
4. Reinstall the front bumper assembly that was removed from Step 2. You will need to use the supplied M8 hardware (A) as shown in Figure 2.
5. Once the bumper assembly is assembled you can tighten the U-bolts from Step 3.
6. Using the instructions provided with your Winch, wire accordingly.

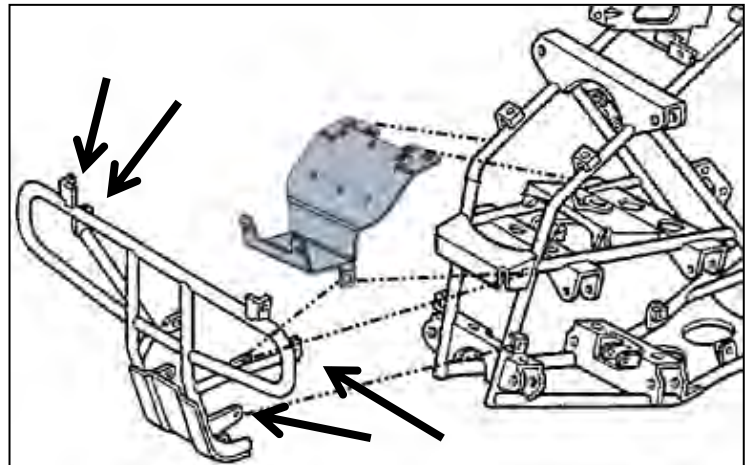

"Figure 1" Remove Bumper assembly and place mount assembly

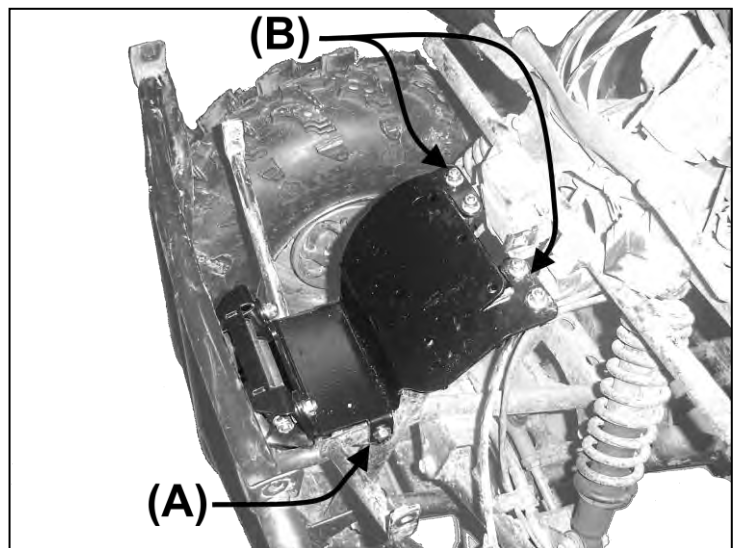

"Figure 2"

