

HONDA BIG RED

Winch Mount

PART # 100870

Hardware Kit: HK-074, HK-031

Kit Components:

Qty.	Part Description
1.....	Mount Plate
1.....	Fairlead Plate
2.....	3/8"-16 x 1 1/4" Flange Bolt
2.....	3/8" USS Flat Washer
4.....	3/8"-16 Nylock Nut
2.....	3/8"-16 x 1 1/2" Bolt
12.....	3/8" SAE Flat Washer
2.....	3/8" Split Lock Washer
1.....	Hardware Kit (Mini-Rocker Switch)

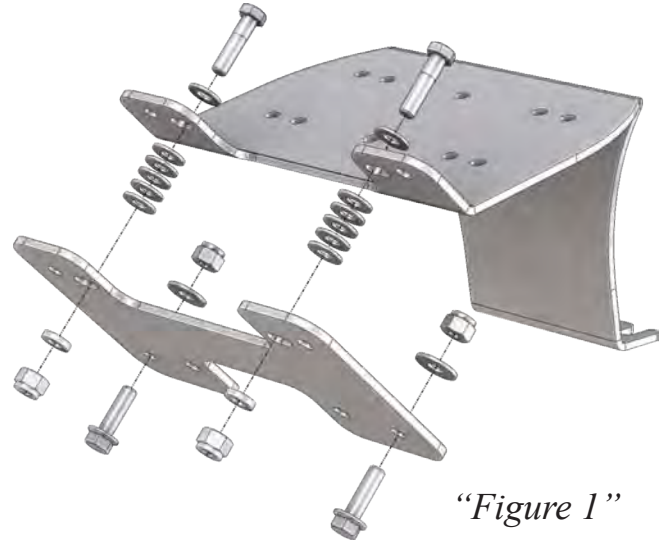

"Figure 1"

INSTALLATION INSTRUCTIONS:

1. To detach front bumper remove bolts (A) on front lower panel as shown in Figure 2.
2. Loosen bolts (B) in front of differential as shown in Figure 3. *These need to have a gap large enough to fit the mount plate in between, approximately 1/4 inch.*
3. Install the winch to the mount plate at this time. *Note: It is much easier to install the wiring to the leads on the winch before installing to machine.*
4. Install winch and mount assembly to machine as shown in Figure 4. Slide mount plate back tight onto front differential bolts (B) and tighten bolts.

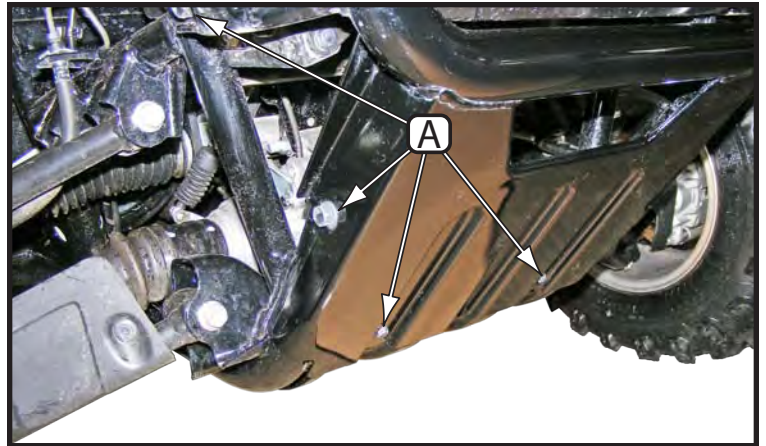

"Figure 2" Bumper Removal



"Figure 4 " Mount Plate/Winch Install

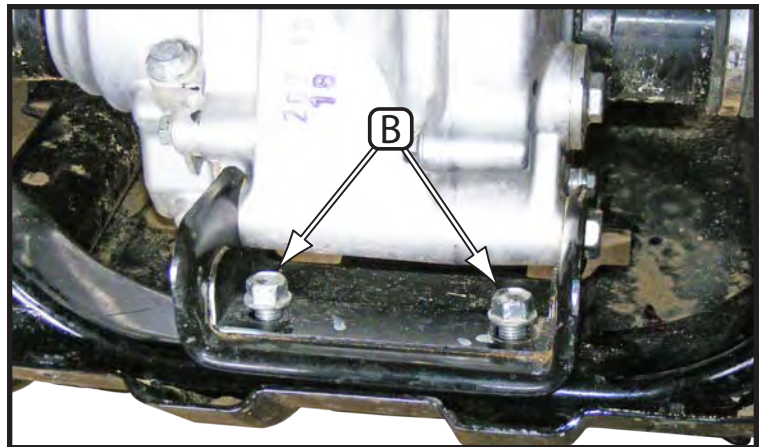

"Figure 3" Front Differential Bolts

- Reinstall front bumper.
- This Mount Plate is designed to work with both Standard and Wide Winches. The Fairlead Plate is made to be reversible, see Figure 5 for details.

For Standard Size Winches (Bolt Pattern 3" x 4.875") - Install your fairlead to the fairlead plate using the hardware provided with your winch. Then install plate and fairlead assembly to the winch mount using the 3/8" x 1 1/2" Bolts, Washers, Lock Washers and Nuts as shown in Figure 6 (C).

For Wide Winches (Bolt Pattern 3" x 6.6") - Install your fairlead and fairlead plate using the 3/8" x 1 1/2" Bolts, Washers and Nuts as shown in Figure 7 (D). Use extra washers as spacers between the fairlead plate and mount plate as shown in Figure 7.

- Drill holes in your bumper with a 3/8" drill bit using holes (E) as your guide and install using 3/8" x 1 1/4" Flange Bolts, Washers and Nuts. (See Figure 8)
- Tighten down all bolts.
- Use the instructions provided with your winch, wire accordingly.

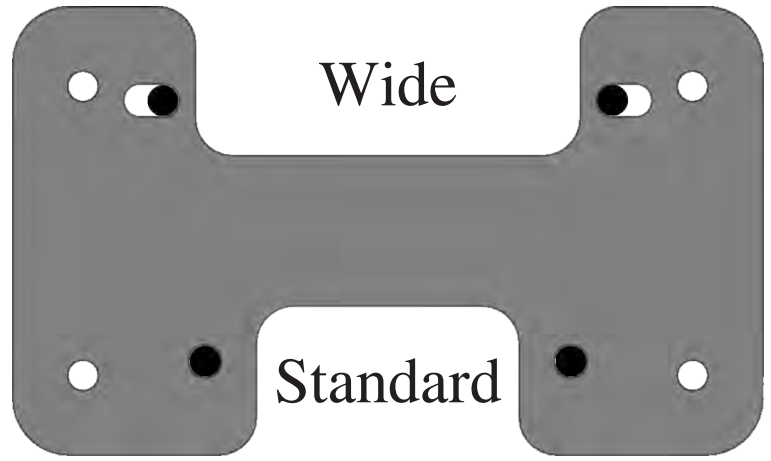

"Figure 5" Fairlead Plate

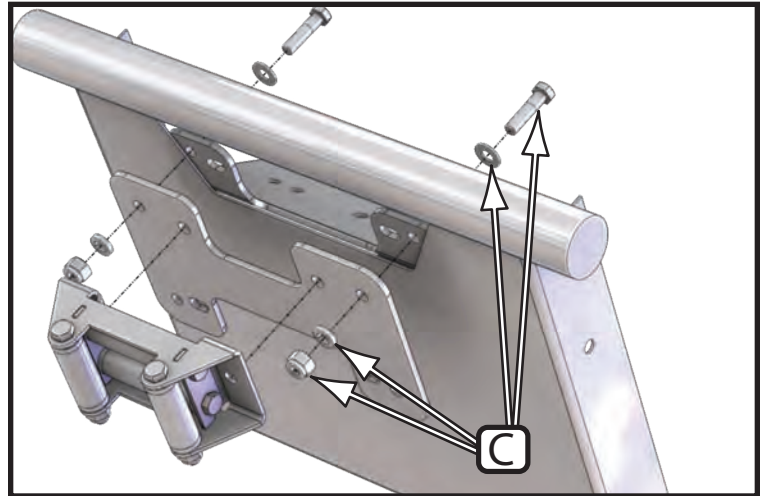

*"Figure 6"
Standard Fairlead and Plate Install
(Winch not shown for clarity)*

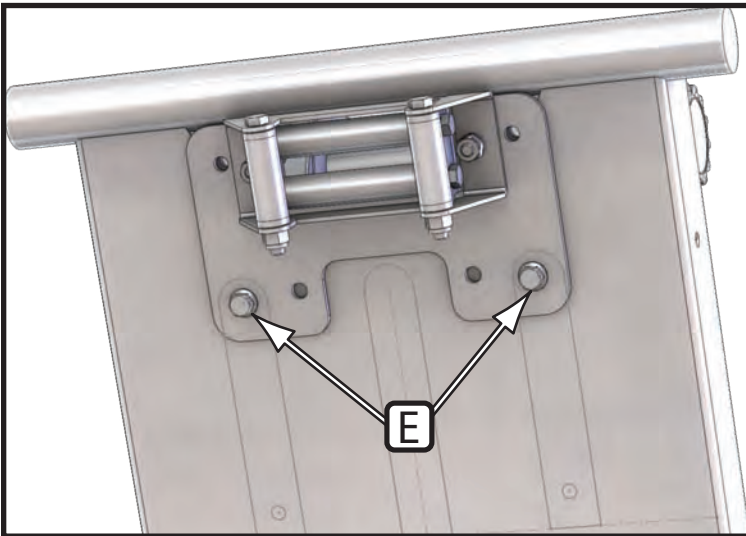

"Figure 8" Fairlead Plate Drill Pattern

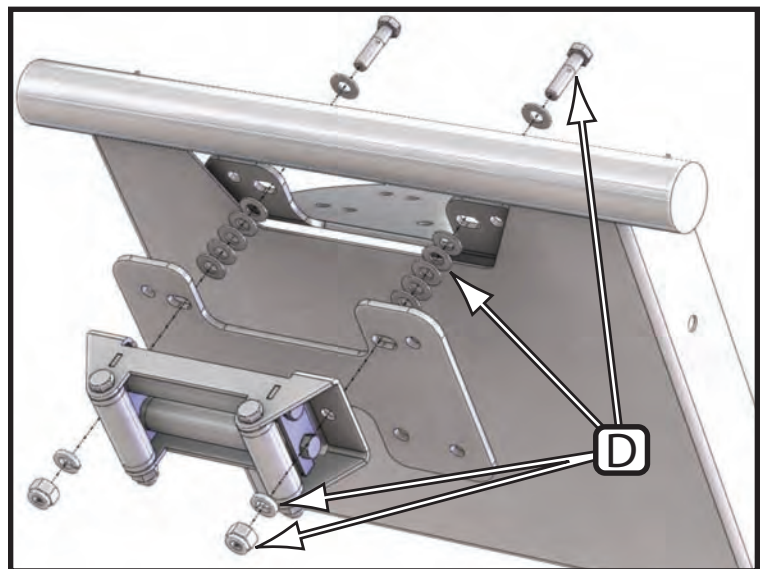

*"Figure 7"
Wide Fairlead and Plate Install
(Winch not shown for clarity)*

