

Honda Pioneer 1000 Front Brush Guard

Front Receiver

Receiver

PART # 101495

Hardware Kit: HK-037

HK-031

Kit Components:

Item #	Qty.	Description
1	1	Receiver Mount
2	1	Bracket
3	2	3/8-16 x 1-1/4" Hex Flange Bolt
4	6	3/8-16 Nylock Nut
5	6	3/8-16 x 3" Flat Washer
6	4	3/8-16 x 1" Shortneck Carriage Bolt
7	3	5/16-18 x 1" Hex Bolt (Not Used)
8	3	5/16" Lock Washer (Not Used)

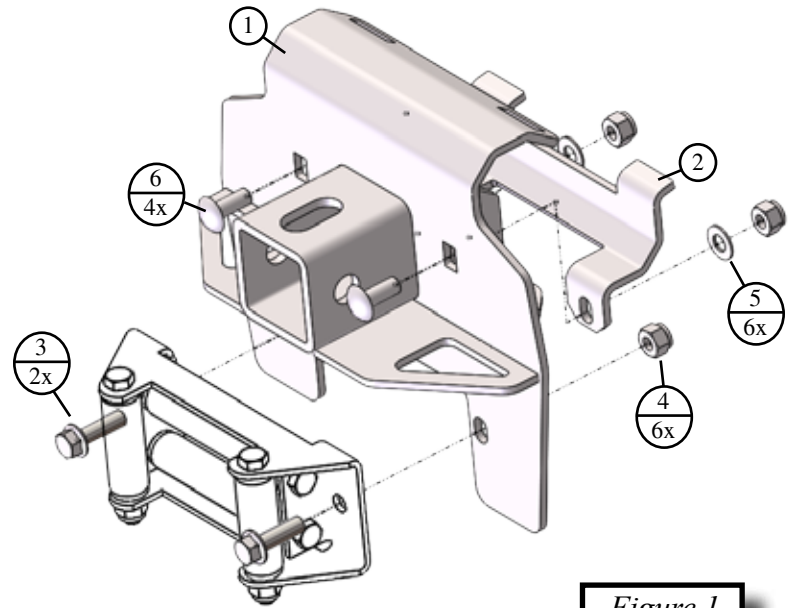

Figure 1

INSTALLATION INSTRUCTIONS:

Note: Make sure all of the hardware needed to complete this mount is in the package. You will not be using all the hardware provided. Read through and understand the instructions before installing.

1. Remove the front bumper. Start by taking off the cap screws (A) holding the plastic to the bumper on each side. Remove the two bolts (B) on the bottom of the bumper as shown in [Figure 2](#), and the four bolts (C) in the bumper tube as shown in [Figure 3](#).

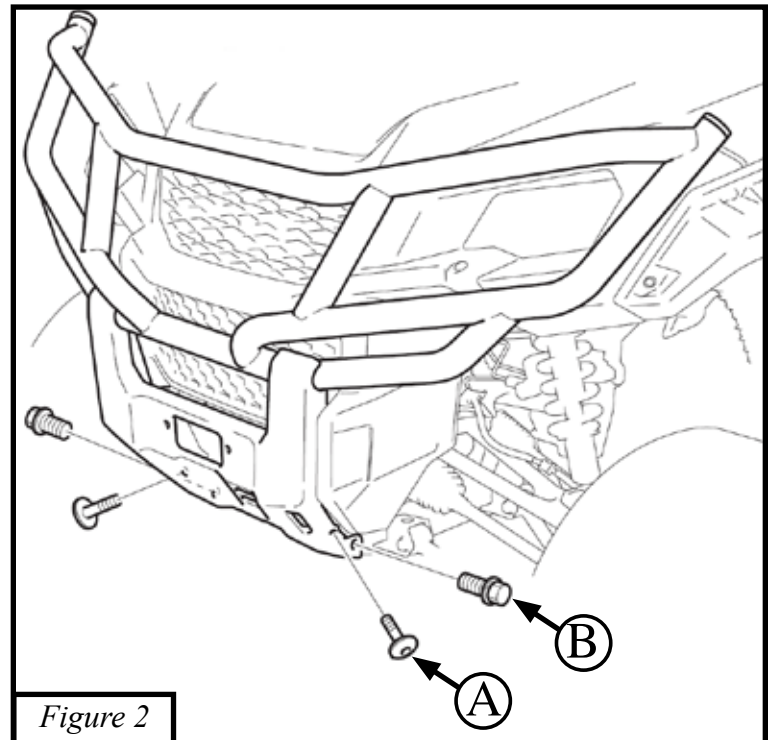

Figure 2

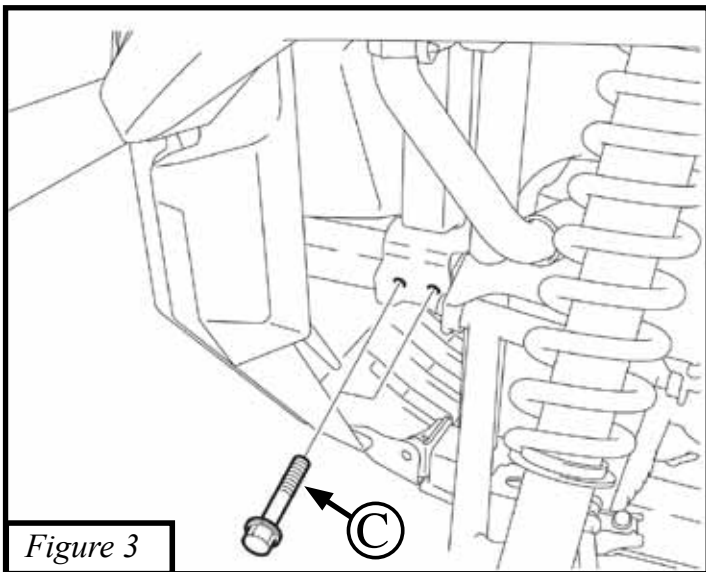

Figure 3

Drivers Side

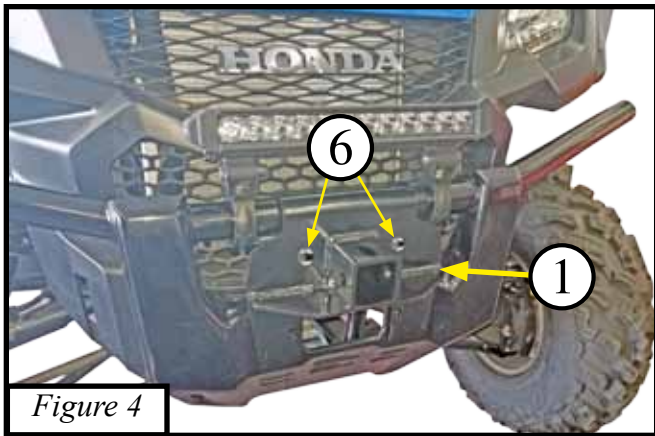

Figure 4

Note: If you have a roller fairlead attached to your bumper from a previous winch install, you will need to removed it at this time.

2. Set the receiver mount (1) on the front of the bumper. Shown in [Figure 4](#).
3. Hook the bracket (2) into the slots on the top of the receiver (1) around the tubing. Shown in [Figure 5](#).

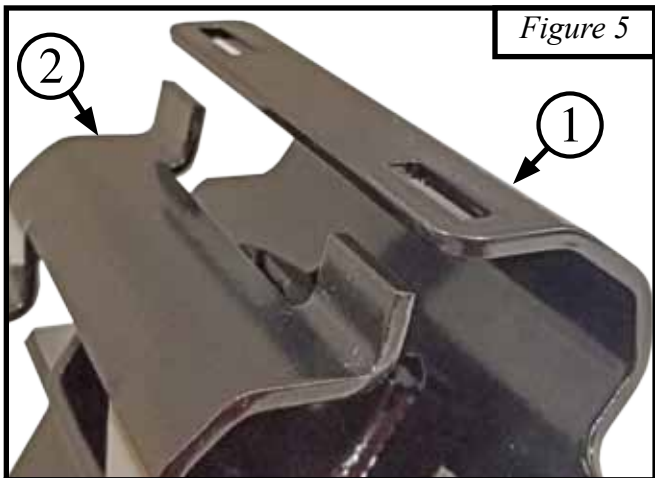

Figure 5



4. Bolt the bracket to the receiver loosely & evenly using the two 3/8 carriage bolts (6), nuts (4) and washers. As shown in [Figures 4 & 6](#).

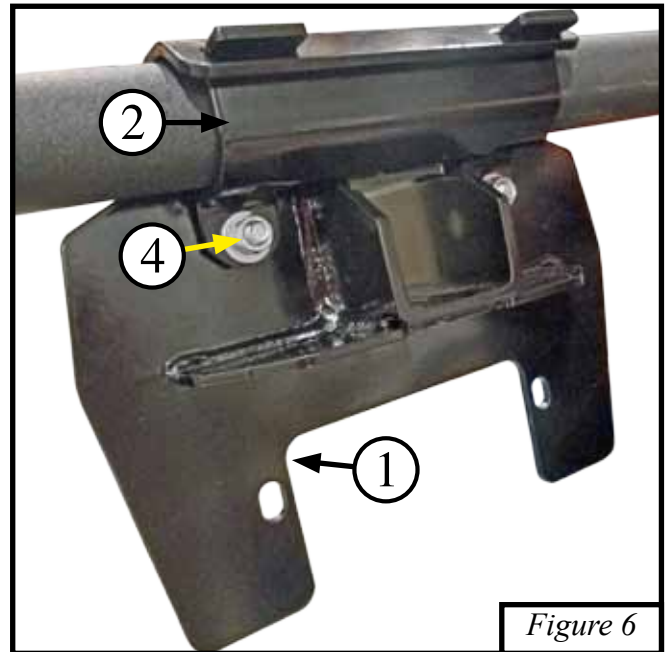

Figure 6

5. Line the receiver mount up with the factory holes for a roller fairlead. If you have a winch continue to [step 6](#) if not skip to [step 7](#).
6. If you have a winch you will need to attach your roller fairlead to the receiver mount and bolt down using the two 3/8 flange bolts and nuts. Shown in [Figure 1](#). (Skip to [Step 8](#).)
7. Attach the lower part of the receiver to your bumper using the 3/8 carriage bolts (6) going through the factory bumper holes.
8. Tighten all of your hardware down to your bumper, making sure that your bracket (2) is tightened evenly.
9. Reattach the bumper to your machine the same way it was removed per instructions above.

