

HONDA RANCHER/FOREMAN

2014-Present

Winch Mount

PART # 102175

Hardware Kit: HK-300

Kit Components:

Qty.	Part Description
1.....	Winch Mount Plate
4.....	5/16"-18 x 3/4" Hex Flange Bolt
4.....	5/16"-18 Nylock Flange Hex Nut
1.....	1/4"-20 x 2" Hex Flange Bolt (NOT USED)
1.....	1/4"-20 x 2" Nylock Flange Hex Nut (NOT USED)

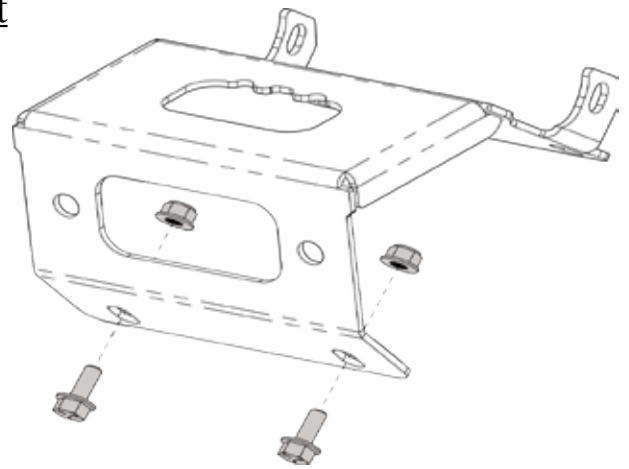

"Figure 1"

INSTALLATION INSTRUCTIONS:

1. Loosen the skid plate by removing 2 Bolts (A) as shown in Figure 2.

Note: The skid plate doesn't need to be removed, it will flex enough that it won't be in the way.

2. Detach front bumper by removing 8 Bolts (B,C,D) and two nuts as shown in Figure 3. Remove bumper from machine.



"Figure 2" Skid Plate

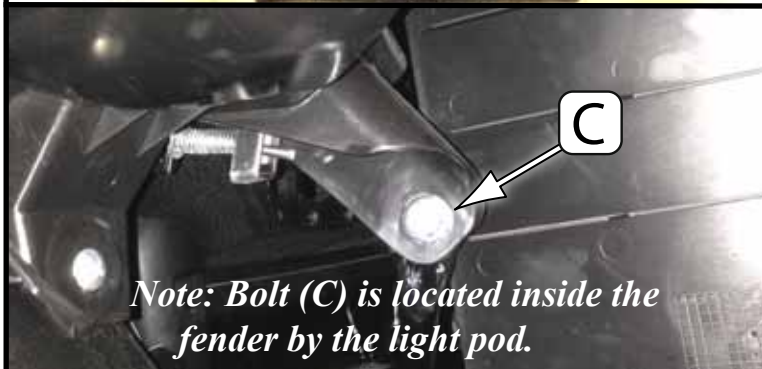
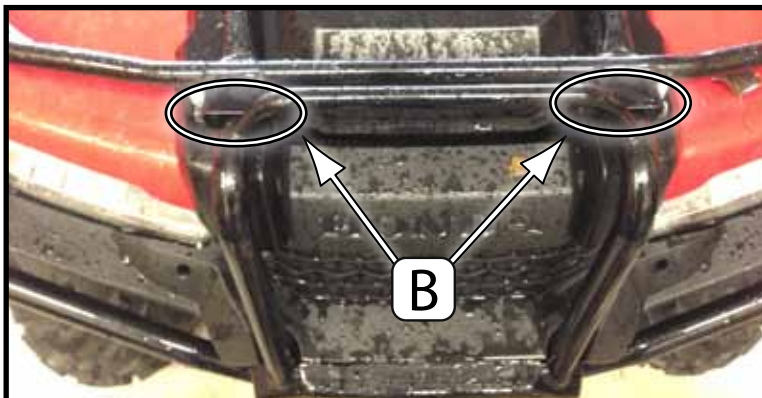

Note: Bolt (C) is located inside the fender by the light pod.

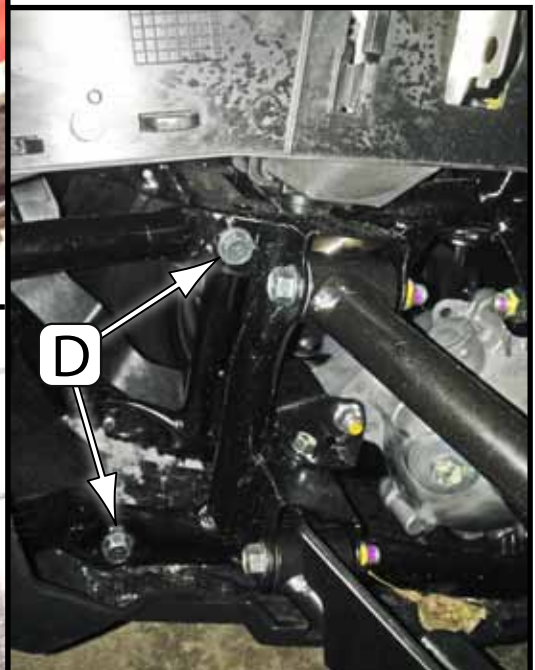

"Figure 3" Front Bumper Removal

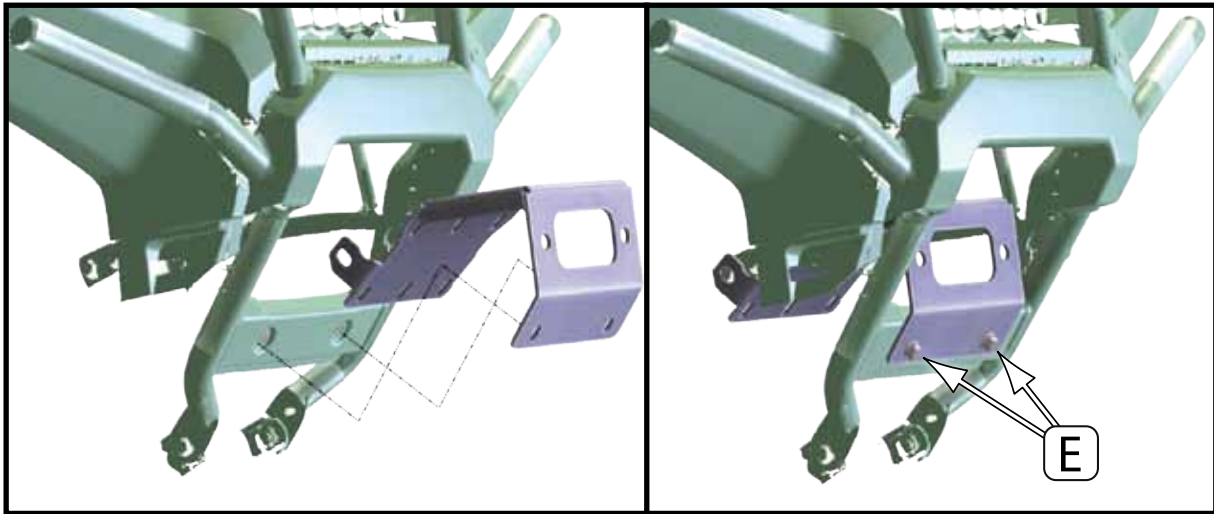

“Figure 4” Mount to Bumper Install

3. With bumper removed, place mount into position as shown in Figure 4. Align front lower mount holes with holes in the lower front bumper. Fasten mount to the lower frame rail using the 5/16” x 3/4” Bolts and Nuts (E), with nuts to the inside of the bumper.

Note: If you have a Superwinch Terra winch you will need to install the bolts from the back instead of the front, so that the nuts are on the outside of the machine.

4. Install your roller fairlead or hawse to the mount plate using the hardware included with your winch. (See Figure 5)
5. Install your winch to the mount plate using the hardware included with your winch. (See Figure 6) Push the winch as far forward as you can and tighten bolts.

Note: Winch needs to be installed as shown so that the cable comes off the bottom of the winch. Some winches including the KFI winch may slightly touch the bumper brace.

6. Replace bumper and mount assembly using bolts removed in step 2.

Note: It is easiest to replace the bumper by installing the two long upper bolts first (B, Figure 3). This allows the bumper to hang while you install the other 6 bolts.

7. Before reinstalling the lower skid plate you may need to trim the plastic on the motor side to fit your winch. Trim the plastic and replace the bolts removed in step 1.
8. Tighten all bolts.
9. Use the instructions provided with your winch, wire accordingly.

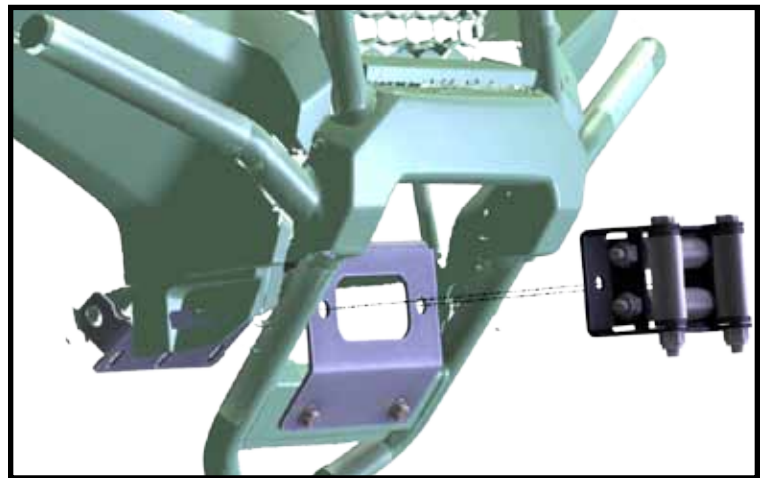

“Figure 5” Fairlead Install

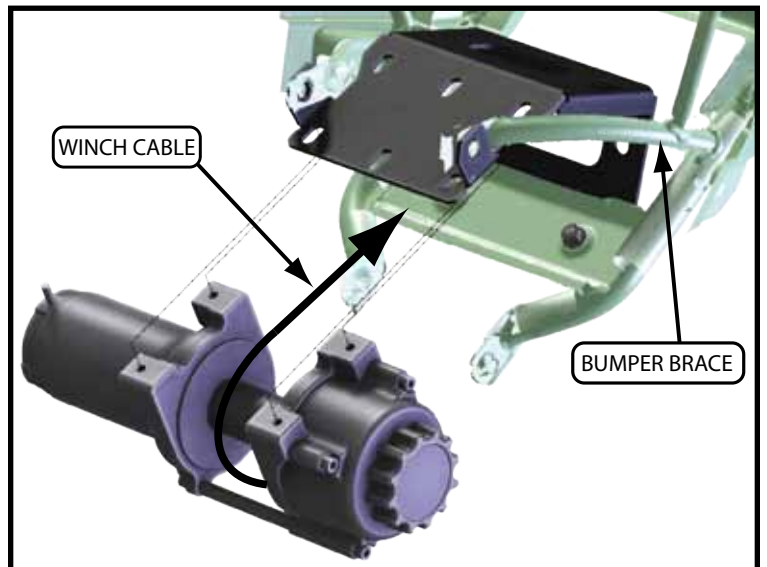

“Figure 6” Winch Install

WIRING INFORMATION

1. For contactor location please see “Figure 7”. This is located behind the battery in the storage compartment. Keep in mind this is just a suggestion.
2. Find a location that suits your purposes for the mini-rocker switch and hand remote.
3. Mini Rocker red wire:
 - a. Wire the red wire from the mini rocker to the ignition controlled wire (white) on the accessory plug as shown in Figure 9 using the supplied connector.
 - b. For all other models wire the red wire from the mini rocker to the ignition controlled wire on the 12V accessory plug. See Figure 10.



“Figure 7” Contactor Location



“Figure 9” Wire Location



*“Figure 8” Battery Location
(Battery is located under the plastic panel behind seat.)*



“Figure 10” Accessory Plug Wire

