

# Polaris Sportsman, ATP & Magnum

Plow Mount                      PART # 105080  
 Hardware Kit: HK-114

## Kit Components:

Qty.	Part Description
1.....	Plow Mount Plate
2.....	Mount Plate Support Bracket
3.....	3/8" Mount Plate Spacer
1.....	3/16" Mount Plate Spacer
2.....	5/16"-18 X 1 1/8" X 1 11/16" SQ U-Bolt
2.....	5/16"-18 X 1 1/8" X 2" SQ U-Bolt
2.....	5/16"-18 X 1 1/8" X 2 3/4" SQ U-Bolt
1.....	5/16-18 x 1 3/4 Carriage Bolt
1.....	5/16-18 x 1 1/4 Carriage Bolt
10.....	5/16-18 Hex Flanged Lock Nut

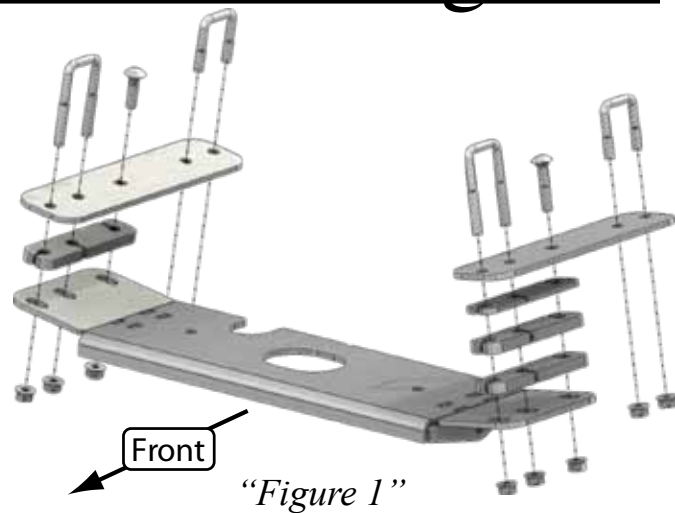

## INSTALLATION INSTRUCTIONS:

1. Remove 4 bolts (A) on drivers side foot rest only. See Figure 2.
2. Place u-bolts on machine frame as shown in Figure 2. Place long u-bolts (B) towards the front of the machine and short u-bolts (C) towards the back as shown in Figure 2.
3. Install mount plate support brackets (D,E) Figure 3&4, with carriage bolts installed, to rear u-bolts using 5/16" flanged lock nuts. Tighten down nuts so plates are still adjustable. **1 3/4" Carriage Bolt goes on drivers side (Figure 4,F) and 1 1/4" Carriage Bolt goes on passenger side (Figure 4,G).**
4. See page 2 for mount plate spacer installation per machine.

**Note: These are only suggestions if a different combination works better on your machine feel free to use it.**

5. Install mount plate loosely to frame using the u-bolts, carriage bolts and 5/16" flanged lock nuts.
6. Adjust plate so oil plug lines up with hole and plate is centered on machine.
7. Tighten down all nuts. Replace 4 driver side foot rest bolts. (Make sure u-bolt ends are even.)
8. See ATV Plow Tube System instruction manual for tube attachment.

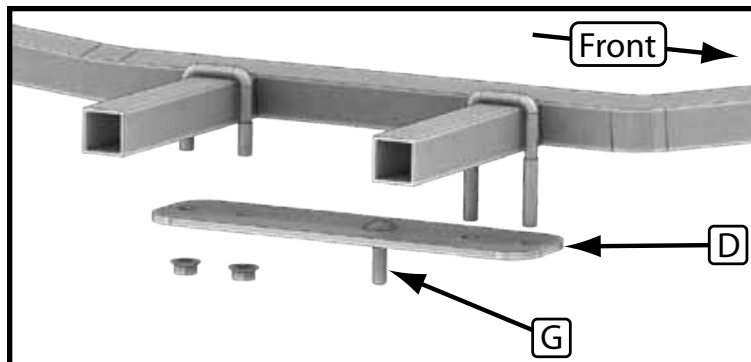
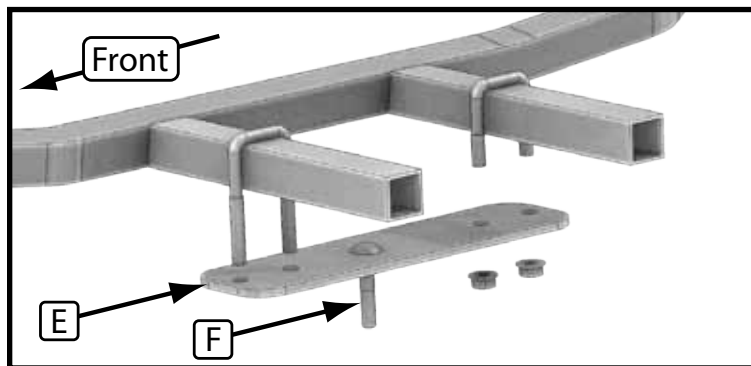
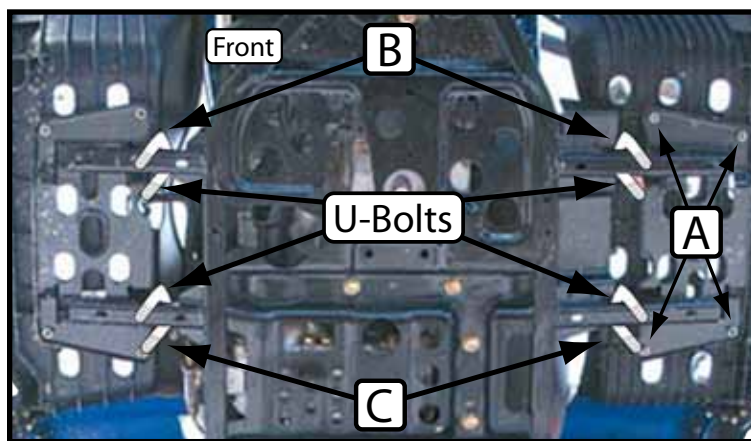

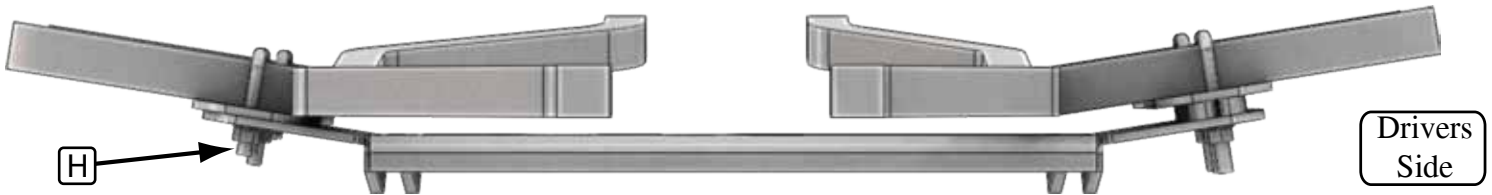

Drivers Side

*Sportsman 600-800*

All Sportsman 600 to 800 ATV's will use one thick spacer on the drivers side of the vehicle. The 2" U-Bolt (H) will be used on the passenger side. After selection of spacers continue with steps 5-7 on page 1.



Drivers Side

*Sportsman 450-500, Magnum 330 (Generation 4)*

The Sportsman 400-500 will use all of the spacers included. On the passengers side it will use one thick spacer and on the drivers side it will use two thick spacers and one thin spacer. After selection of spacers continue with steps 5-7 on page 1.



Drivers Side

*Sportsman ATP*

The Sportsman ATP will not use any spacers on either side of the vehicle. Two optional thick spacers can be used between the mount and nuts to shorten up the ends of the u-bolts. After selection of spacers continue with steps 5-7 on page 1.

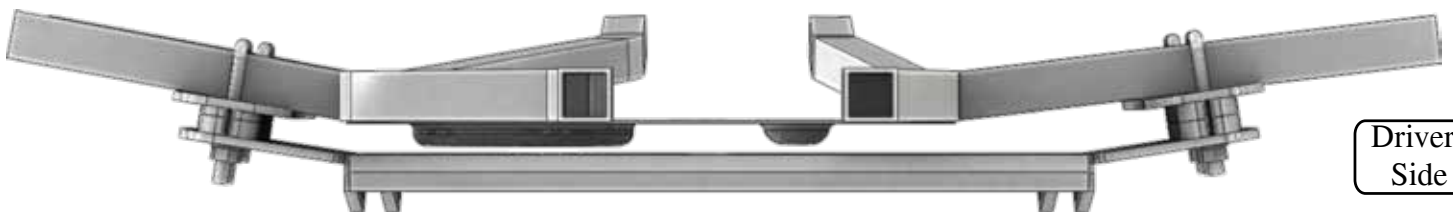

Drivers Side

*Sportsman 500 H.O.*

The Sportsman 500 H.O. will use all of the spacers included. On the passengers side it will use one thick spacer, one thin spacer and on the drivers side it will use two thick spacers. After selection of spacers continue with steps 5-7 on page 1.



Drivers Side

*Sportsman ETX/570*

The Sportsman ETX and 570 will use one thick spacers on both sides of the vehicle. After selection of spacers continue with steps 5-7 on page 1.

**Note:**

*If preferred, after full installation of mount plate and tightening of nuts, u-bolt ends may be cut down.*