

C FORCE 800/1000 G3

Plow Mount

PART #106695 Rev A

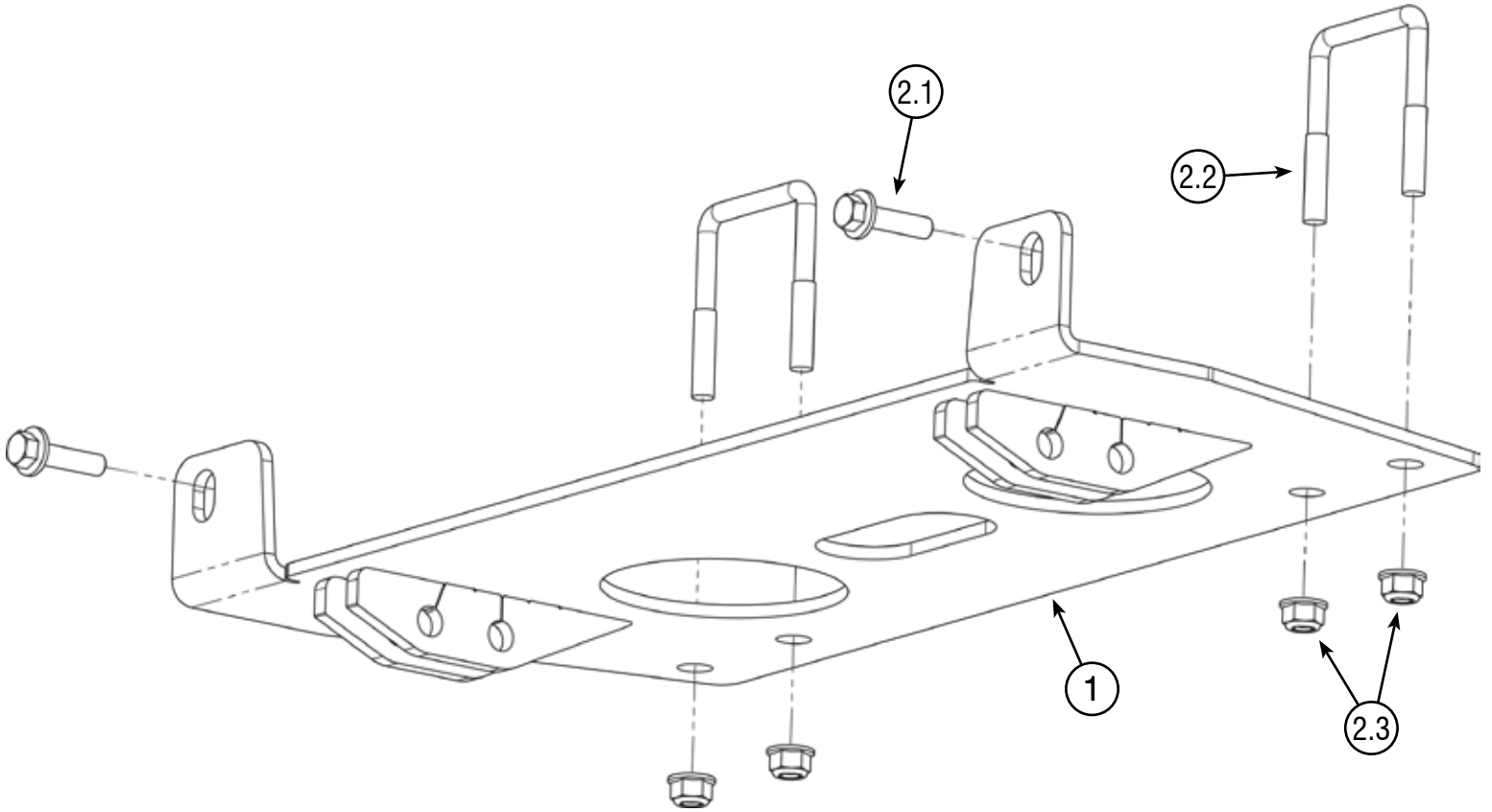

Kit Components:

Item #	Qty.	Description	Item #	Qty.	Description
1	1	Plow Mount (106696)	2.3	4	5/16"-18 Hex Nut Flange Nylock Zinc GR5
2	1	Hardware Kit HK-377	2.4	2	M8 Flat Washer Zinc (Not Used)
2.1	2	M8-1.25 x 30 Hex Flange Bolt	2.5	2	M8-1.25 Hex Nut Nylock Zinc (Not Used)
2.2	2	5/16"-18 x 2.00" x 2.50" SQ U-Bolt Zinc 1.25" Thread			



INSTALLATION INSTRUCTIONS

Notice

Torque bolts to ANSI Specs (or OEM specs if applicable), unless otherwise stated. After the first use and at the start of each season, check torque.

Note: Make sure all hardware needed to complete this mount is in the package. Thoroughly read through and understand the instructions before installing.

Installation Instructions

1. To allow for more room to work, unclip the plastic inner fender well (B). Remove Bolts (A) on the front side of each foot peg. See **Figure 1**. Set bolts (A) aside as they will not be reused.
2. Install Plow Mount (1) into place using bolts (2.1). With the front bolts installed, use the mount as a template to mark the rear inner holes (C) for drilling through the plastic skid plate. See **Figure 2**.
3. After marking the holes, remove Bolts (2.1) and set Plow Mount (1) aside. Remove Skid plate (D) from bottom of machine by removing 9x skid plate bolts (3x on the passenger side, 3x on the drivers side, and 3x on the bottom).
4. Once skid plate (D) is removed, drill marked points using a 1/2" drill bit. See **Figure 3**.
5. Place U-bolts (2.2) over the frame like shown in **Figure 4**. **It is important to be sure the U-bolt on the passenger side goes between the frame and the brake lines.**
6. Reinstall the skid plate (D), making sure the U-bolts (2.2) come through the holes drilled in **Step 4**. Loosely install Plow Mount using bolts (2.1). Next, with the U-Bolts (2.2) coming through the plow mount, loosely install Nuts (2.3) onto the U-bolts.
7. Once all hardware is started, tighten all hardware evenly.

