

V PLOW DASH ROCKER SWITCHES

PART #106180-AP Rev A

Kit Components 106180-AP		
Item #	Qty.	Dash Rocker Switch Kit
1	2	Dash Rocker Switch (ACT-BLDRS-K)
2	2	Main Actuator Harness (ACT-HAR)

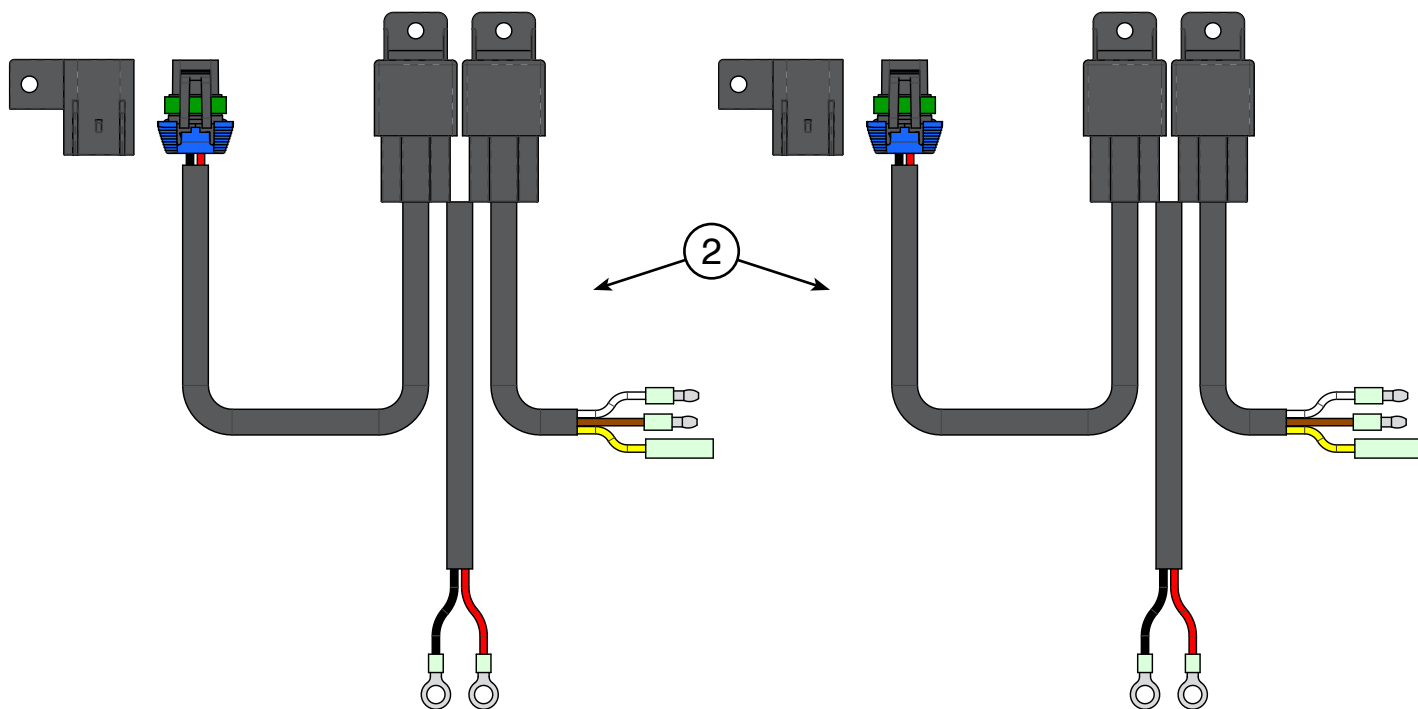
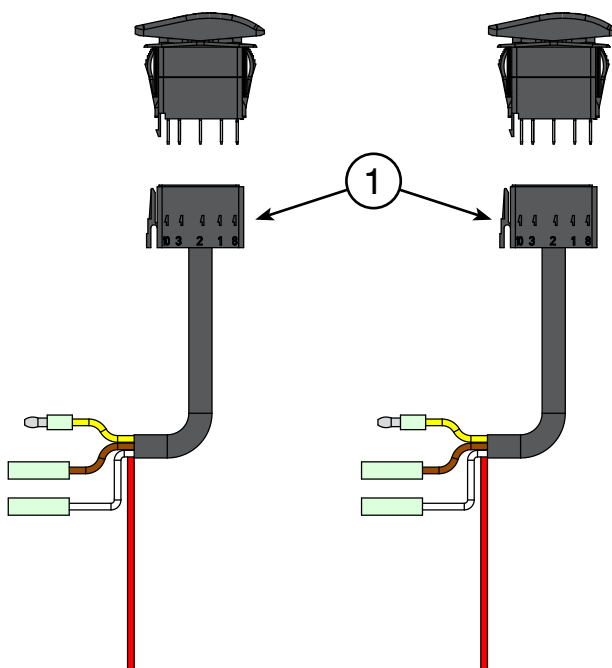

WIRING INSTRUCTIONS 106180-AP

Figure 1

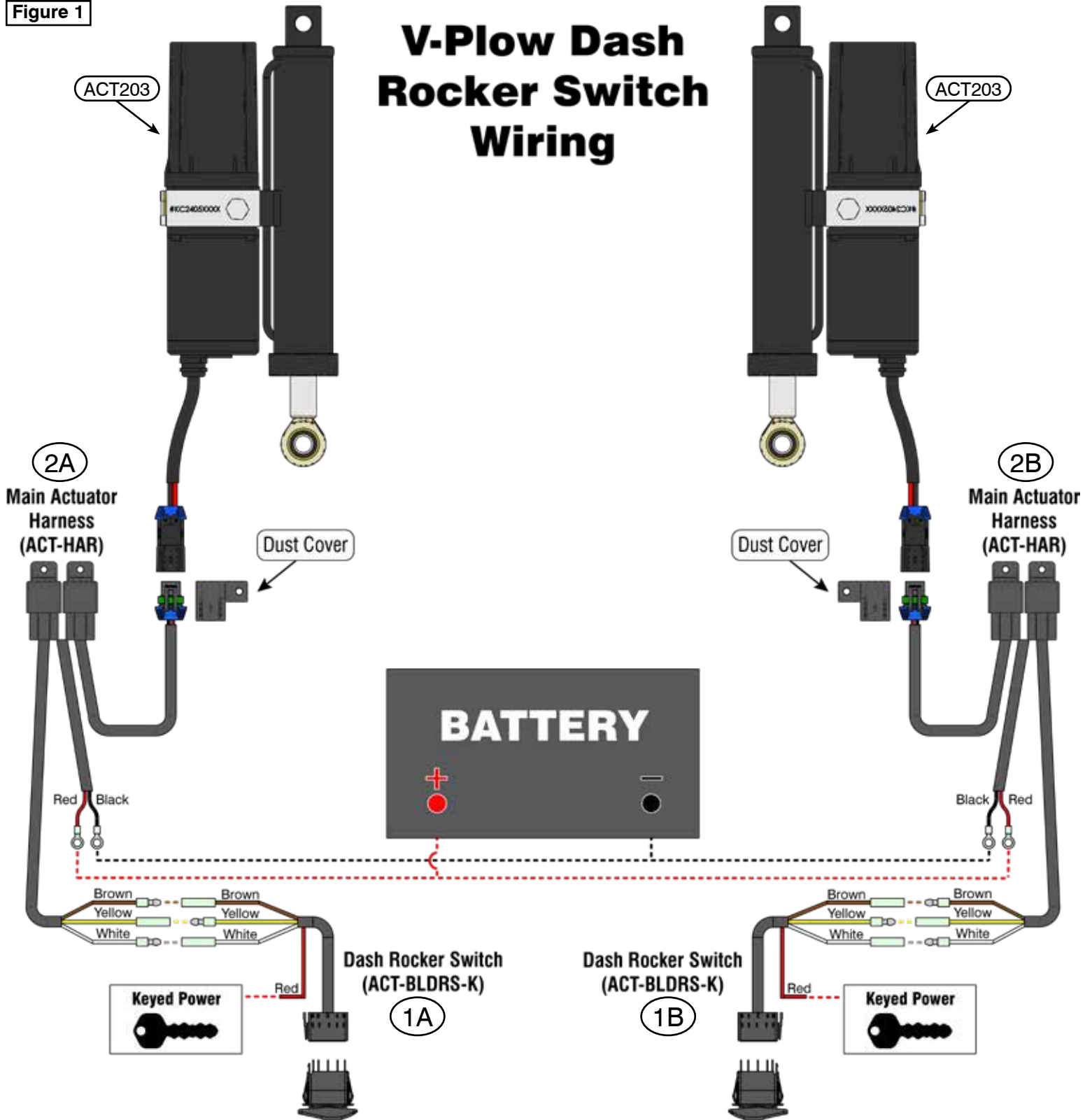

WIRING INSTRUCTIONS 106180-AP

Notice

Be careful to not crimp/cut any wires during the install. Keep wires away from sharp and hot objects when securing to the machine.

Note: Make sure components needed to complete this installation are in the package. Thoroughly read through and understand the instructions before installing.

Installation Instructions

1. Connect the Red and Black wires from both of the **Main Actuator Harnesses (2A and 2B)** to the battery. See **Figure 1** for reference.
 - Red wires to the Positive (+) terminal
 - Black wires to the Negative (-) terminal
2. Splice the end of the red wires from both of the **Dash Rocker Switches (1A and 1B)** into a power source that is controlled by the ignition (Keyed Power). Use a test light to identify a wire that receives power only when the key is in the ON position.
3. Connect the Brown, Yellow, and White wires from one of the **Dash Rocker Switches (1A)** to one of the **Main Actuator Harnesses (2A)**:
 - Brown (Female) to Brown (Male)
 - Yellow (Male) to Yellow (Female)
 - White (Female) to White (Male)
4. Repeat Step 3 for the other **Dash Rocker Switch (1B)** and the other **Main Actuator Harness (2B)**. See **Figure 1**.
5. Find a clean and dry location to mount the relays. Make sure the location you choose allows sufficient clearance from all metal components. Keep away from sharp and hot objects when securing. Drill a mounting hole if required. Secure with zip ties or self tapping screws.
6. Use zip ties to secure the dust covers on the **Main Actuator Harnesses (2A and 2B)** to the front of the machine. Ensure they are positioned so the plugs going to the actuator (ACT203) can be easily connected when the plow is not in use.

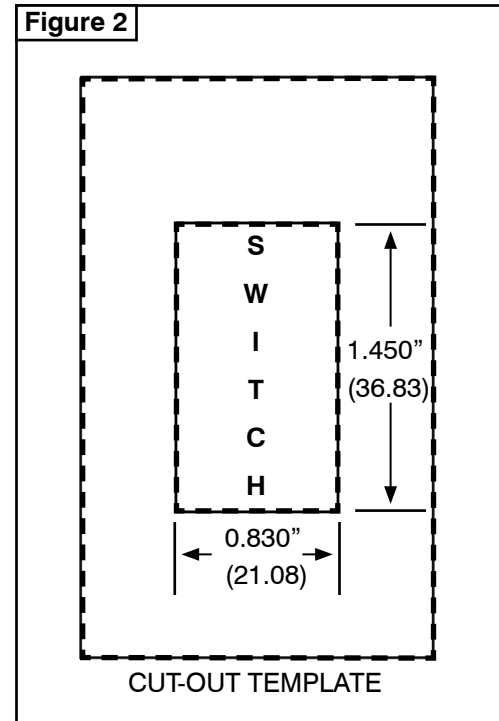

AFTER PRINTING, LINE BELOW SHOULD MEASURE 1"

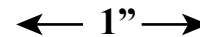

PRO-V PLOW HAND REMOTE UPGRADE

1. KFI offers a V-plow hand remote that allows users to control the plow with pre-programmed settings and full articulation of each actuator, all from a single remote.
2. This system can be integrated into your current setup by installing a **Hand Remote Harness**, which connects to the **Main Actuator Harnesses** and the existing **Dash Rocker Switches**.
3. If you are interested in adding this option to your Pro-V plow set up, please give your local dealer or KFI a call to get more information.

